

# **INFINICAM UC-1**

**Hardware Manual**

**Rev. 4.03 E**

**Photron**

#### **WARNING**

This equipment has been tested and found to comply with the limits for a Class A digital device, pursuant to part 15 of the FCC Rules. These limits are designed to provide reasonable protection against harmful interference when the equipment is operated in a commercial environment. This equipment generates, uses, and can radiate radio frequency energy and, if not installed and used in accordance with the instruction manual, may cause harmful interference to radio communications. Operation of this equipment in a residential area is likely to cause harmful interference in which case the user will be required to correct the interference at his own expense.

#### **CAUTION:**

Any changes or modifications not expressly approved by the party responsible for compliance could void the user's authority to operate the equipment.

The copyright of this manual is held by PHOTRON LIMITED.

Product specifications and manual contents are subject to change without notice.

PHOTRON LIMITED bears no responsibility for any results by using our products nor by applying this manual to any operations.

# Introduction

Thank you for your purchase of Photron's high-speed camera system, the "INFINICAM UC-1" (referred to below as the system).

This manual contains the operating instructions and warnings necessary for using the system. Before using the system, read the entire manual.

If any part of this manual is unclear, contact Photron using the contact information printed at the back of the manual.

After you finish reading the manual, store it in a safe place along with the warranty card and refer back to it when necessary.

# Using the Manual

This section explains the layout of the manual.

- **Introduction**

The introduction explains the manual and safety precautions.

- **Chapter 1, Setup**

This chapter gives an overview of the components that make up the system.

- **Chapter 2, Product Specifications**

This chapter explains the system's specifications.

- **Chapter 3, Warranty**





This chapter explains about the warranty.

- **Chapter 4, Contacting Photron**

This chapter lists the contact information to use when contacting Photron if the system malfunctions or if a portion of the manual is unclear.

# Manual Notation

The following icons and symbols are used in the explanations in this manual.

Icon/Symbol	Description
 <b>IMPORTANT</b>	This symbol indicates content that should always be read.
 <b>CAUTION</b>	This symbol indicates instructions that should always be followed when using the software, or things to be careful of when using the software.
 <b>NOTE</b>	This symbol indicates supplementary items to be aware of when using the system.
 <b>REFERENCE</b>	This symbol indicates the location of a reference.
“ ”	This symbol is used to indicate the names of items on a screen, references, dialog names, and connectors.
[ ]	This symbol is used to indicate menu names, and sub-menu names.

## Using the System Safely and Correctly

In order to prevent injury to yourself and others, and to prevent damage to property, carefully observe the following safety precautions.

Photron has given its full attention to the safety of this system. However, the extent of damage and injury potentially caused by ignoring the content of the safety precautions and using the system incorrectly is explained next. Pay careful attention to the content of the safety precautions when using the system.



**Warning**

This symbol indicates actions that carry the risk that a person could receive a serious injury.



**Caution**

This symbol indicates actions that carry the risk that a person could receive a moderate injury, or that damage to physical property might occur.

- The safety precautions to be observed are explained with the following symbols.



This symbol indicates actions that require caution.



This symbol indicates actions that are prohibited and must be avoided.



This symbol indicates actions that must always be performed.



## Warning



- Do not perform actions that will damage the USB cable.

Do not damage the cable, modify it, use it near a heater, excessively bend, twist or pull on it, place heavy objects on it, or bundle it.

Using the cable when damaged can cause fire, electric shock, or a short circuit.



- Do not insert metallic objects inside, or pour liquids such as water on, the system.

Doing so can cause fire, electric shock, or malfunction from short circuit or heat.



- Do not disassemble or modify the system.

There are high voltages inside the system that can cause electric shock.



- Do not plug in or unplug the USB cable with wet hands.

Doing so can cause electric shock.



- Make sure the USB cable is fully insert into the socket.

Not fully plugging in the cable can cause fire from electric shock or heat.



- When something is wrong with the system, unplug the USB cable immediately.

- When a foreign substance or liquid, such as metal or water, gets inside.

- When the outer case is broken or damaged, such as from a fall.

- When the system emits smoke, a strange smell, or strange sound.

Using the system in these conditions might cause a fire or electric shock.



- Do not use the accessories by the usage that a manufacturer does not specify.

It may cause damage of protection.

 **Caution**

- Always unplug the system when cleaning it or when it is unused for a long period of time. Leaving or storing the system connected to the power source might cause fire from insulation deterioration or electrical discharge.



- Do not install a screw beyond the specified depth to the tripod adapter. Doing so causes scratches or deformation to the camera body and failure of the camera.



- The sample application and the SDK have the function to stop the camera's fan, but the fan will not automatically restart after a fan is stopped. Leaving it stopped will cause the camera to overheat and stop or fail. In the SDK, use the `PUC_GetSensorTemperature` function to restart the fan so that the camera does not exceed 85 °C.



- Consult us in advance when you perform an event by which laser light or direct rays fall on the image sensor surface.



- Do not set the system in a location where the temperature gets unusually hot. The trunk and inside of a car can get especially hot in summer. Doing so can cause the outer case and internal components to deteriorate or cause a fire.



- Do not place the system in a location prone to oily smoke or steam, or in a location with a lot of humidity or dust. Oil, moisture, and dust conduct electricity, which can cause a fire or electric shock.



- Ambient temperature 0 to 40 °C, humidity 80 % RH or lower, maximum altitude 2,000 m or lower, and use in a condensation-free environment. Use in a condition out of the above limits can cause malfunction.



- Do not store the equipment in a location where the temperature goes below -20 °C or higher than 60 °C. Be sure not to allow condensation to form inside the system.





- When shipping, remove the connecting cable and use the original packaging. Do not ship the equipment in an environment where the temperature goes below  $-20\text{ }^{\circ}\text{C}$  or higher than  $60\text{ }^{\circ}\text{C}$ . Also, prevent condensation from forming during shipment.



- When installing the camera with a tripod, check the tripod load capacity and be careful not to exceed the load bearing capacity. Also, when using a tripod, make sure that the tripod, tripod screw, panhead, and others are properly set, and be careful not to let the tripod fall down.



## European Union (and EEA) only



“CE” mark indicates that this product complies with the European requirements for safety, health, environment, and customer protection. “CE” mark equipments are intended for sales in Europe.



This symbol indicates that this product is not to be disposed of with your household waste, according to the WEEE Directive (2002/96/EC) and/or your national laws implementing the Directive.



This product should be handed over to a designated collection point, e.g., on an authorized one-for-one basis when you buy a new similar product or to an authorized collection site for recycling waste electrical and electronic equipment (EEE) and batteries and accumulators. Improper handling of this type of waste could have a possible impact on the environment and human health due to potentially hazardous substances that are generally associated with EEE. Your cooperation in the correct disposal of this product will contribute to the effective usage of natural resources.

For more information about the recycling of this product, contact your local city office, waste authority, approved scheme or your household waste disposal service or visit [www.photron.com](http://www.photron.com).

(EEA: Norway, Iceland, and Liechtenstein)



This product is in conformity with the protection requirements of EU Council Directive 2014/30/EU (Class A) on the approximation of the laws of the Member States relating to electromagnetic compatibility.

**Warning:** This is a Class A product. In a domestic environment, this product may cause radio interference, in which case the user may be required to take adequate measures.



### Manufacturer's contact

#### **PHOTRON LIMITED**

21F, Jinbocho Mitsui Bldg., 1-105 Kanda Jimbocho, Chiyoda-Ku, Tokyo 101-0051, Japan

Phone: +81 (3) 3518 6271

Fax: +81 (3) 3518 6279

E-mail / Web: [image@photron.co.jp](mailto:image@photron.co.jp) / [www.photron.co.jp](http://www.photron.co.jp)



### European contact

#### **Photron Deutschland GmbH**

Ziegelweg 3, 72764 Reutlingen, Germany

Phone: +49 (0) 7121 699 7950

Fax: +49 (0) 7121 699 7943

E-mail / Web: [image@photron.com](mailto:image@photron.com) / [www.photron.com](http://www.photron.com)



## Cleaning of the Image Sensor Surface

Electrostatic Discharge (ESD) events may cause immediate and unrecoverable damage to the image sensor.

Read the following instructions and take **EXTREME CARE** when cleaning the image sensor surface.



- ALWAYS take appropriate anti-static precautions when cleaning or working near the Image sensor.
- DO NOT use any form of cleaning equipment using electrostatic or 'charged fiber' technology.



- Discharge any electrostatic build up in your body by touching a grounded metallic surface before working near the camera sensor.
- Very gently, use only clean and dry air to remove dust from surface of the image sensor.
- To remove stubborn contamination, use the highest grade (e.g. VLSI grade) pure Isopropyl alcohol (IPA) with optical wipes of 'clean room' grade.
- Extreme care must be taken! Gently wipe across the sensor in a single action.  
**DO NOT rub to avoid abrasive damage to delicate optical coatings on the glass surface.**

# Contents

<b>Chapter 1 Setup</b>	<b>1</b>
1.1 System's Component .....	2
1.1.1 Component .....	2
1.2 Part Names .....	3
1.2.1 Camera Body .....	3
1.2.2 Camera Body Part Names .....	4
1.2.3 Status Display LEDs on the Rear of the Camera Body .....	6
1.2.4 Power Supply Connector (USB3.1 Type-C) .....	7
1.3 Input/Output Signal Types .....	8
1.3.1 SYNC IN .....	8
1.3.2 SYNC OUT .....	8
1.3.3 SYNC IN, OUT Circuit Diagram .....	9
1.3.4 Using External Synchronization Signals .....	10
1.3.5 Synchronization with a variable frequency .....	10
1.4 Device Connections .....	11
1.4.1 Minimum Equipment Connection .....	11
<b>Chapter 2 Product Specifications</b>	<b>12</b>
2.1 Specifications .....	13
2.1.1 Product Specifications .....	13
2.1.2 General Specifications .....	13
2.1.3 Frame rate and Resolution .....	14
2.1.4 Shutter Speed List .....	14
<b>Chapter 3 Warranty</b>	<b>15</b>
3.1 About the Warranty .....	16
<b>Chapter 4 Contacting Photron</b>	<b>17</b>
4.1 Contact Information .....	18

# 1

## Chapter 1 Setup

This chapter gives an overview of the components that make up the system.

# 1.1 System's Component

## 1.1.1 Component

This product's standard component is as follows.

1. The main unit of INFINICAM (C-Mount, Cap included)



### CAUTION

PC, lens, and USB 3.1 Type-C cable, which is the minimum requirement for use of the system, is sold separately.



### NOTE

Contact Photron for sample software, SDKs, and other technical information.

## 1.2 Part Names

The system is composed of components including the camera body and the SDK (including sample software).



For the camera body

- Do not expose the camera body and other optional components to shock.
- Do not use in an area where flammable gas or dust is present.
- Do not place in an unstable location such as on an unstable platform or an incline.
- Do not disassemble or modify.
- Do not expose to liquids such as water.
- Do not subject to an excessive force.

### 1.2.1 Camera Body

The camera main unit is designed to compress and transfer high speed recorded image data from the sensor to PC and process the data in real-time image processing. The top surface of the main unit is equipped with a USB3.1 Type-C interface to connect to PC and an input/output connector (DIN connector) for external synchronization signals.



## 1.2.2 Camera Body Part Names





Tripod Adapter

Tripod Screw Hole  
(1/4-inch, 6 mm)





**\* Caution**

Installing a screw beyond the specified depth will lead to scratches or deformation to the camera body and failure of the camera.

## 1.2.3 Status Display LEDs on the Rear of the Camera Body

There are a number of LEDs on the rear of the system's camera body. These LEDs indicate the status of the system. The function of each LED is explained here.



Item	Color	ON	FLASHING	OFF
POWER		Power On	—	Power Off
SYNC		Synchronization signal is not input in external synchronization mode	Synchronization signal is input in external synchronization mode	Internal synchronization mode
USB		—	Operating normally with the software (SDK)	<ul style="list-style-type: none"> <li>• Power Off</li> <li>• When the software (SDK) is not recognized</li> <li>• During Continuous transfer mode</li> </ul>

## 1.2.4 Power Supply Connector (USB3.1 Type-C)

This is a power supply input / data communication connector from PC.



### Warning

Do not use a power supply which does not meet the system's specifications, or a power supply you cannot guarantee the safety of.

By using a power supply out of the system specifications, not only is there the danger of the system malfunctioning, but also of fire and electric shock.



### CAUTION

- Note that the Type-C connector will only work on either direction (upside-up or upside-down) of the connector depending on the specifications of the cable.
- Depending on the specifications of the cable, such as a charge-only cable or a USB2.0 cable, it may not work.

## 1.3 Input/Output Signal Types

With the system, Sync signal can be input / output through the I/O connector (on the top surface).



A signal other than the specified signal must not be input to the respective connectors.

Use extreme caution as there is a risk of damage to both, the input device, and the output device.

### 1.3.1 SYNC IN

The system recognizes a TTL signal from other devices as a synchronization signal.

The input voltage is 2.5Vp-p, positive polarity, pulse width is 200 nsec or greater.

Setting	Description	Signal (Input Signal Conditions)
SYNC POS	Inputs the signal with positive polarity. Input the synchronization signal from the camera or external device.	2.5Vp-p, Positive Polarity, 200 nsec or greater

### 1.3.2 SYNC OUT

The synchronization signal to be output from the system can be selected and set from the following settings.

The output voltage is 2.5Vp-p, positive or negative polarity, pulse width is 11.5 nsec or greater.

Setting	Description	Signal (Output Signal Conditions)
SYNC POS	Outputs the signal with positive polarity. Outputs the synchronization signal from the camera or external device.	2.5Vp-p, Positive Polarity
SYNC NEG	Outputs the signal with negative polarity. Outputs the synchronization signal from the camera or external device.	2.5Vp-p, Negative Polarity

### 1.3.3 SYNC IN, OUT Circuit Diagram

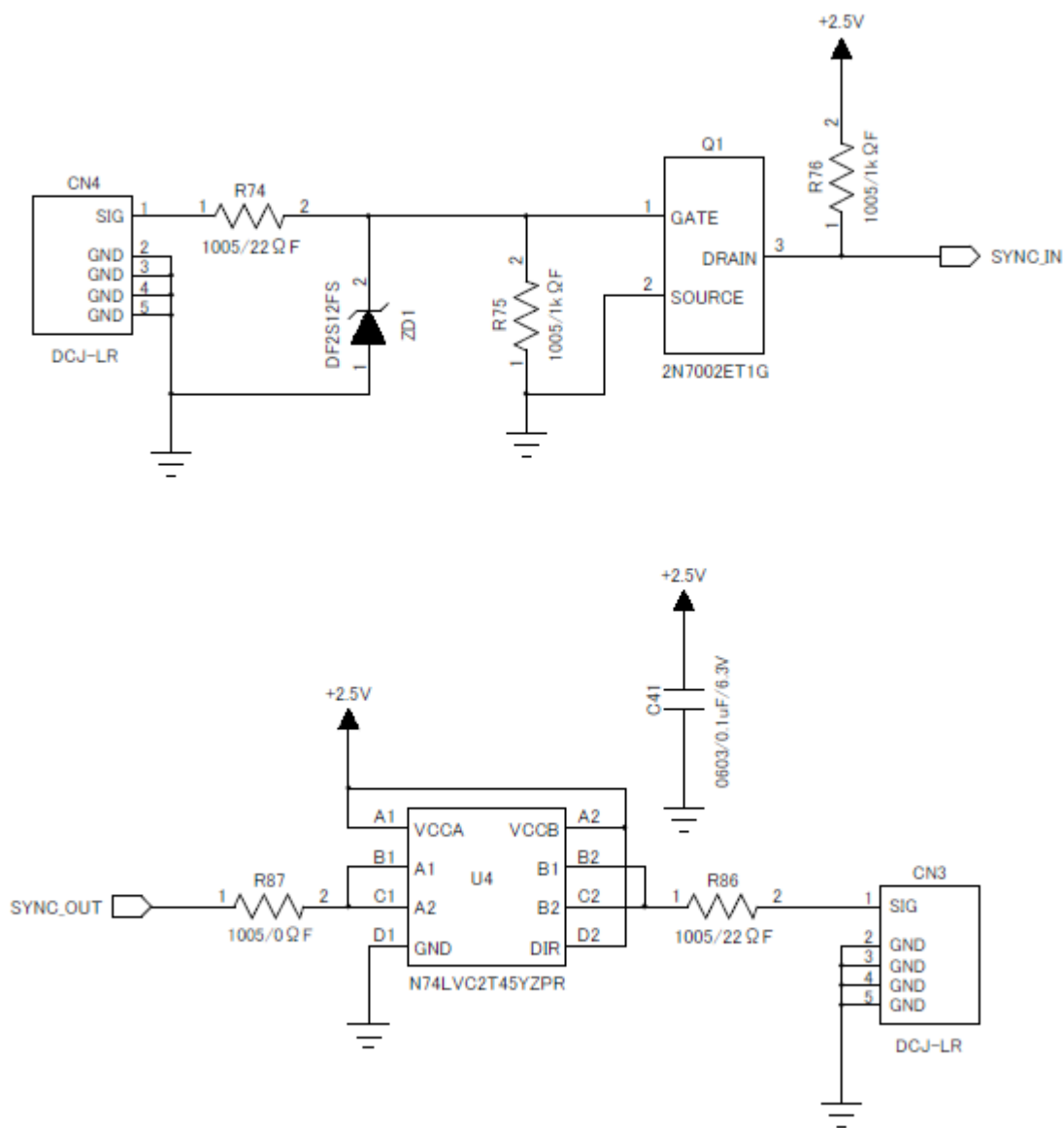

## 1.3.4 Using External Synchronization Signals

An external synchronization mode to synchronize to an external signal is provided on the system. By using an external synchronization signal, recording can be conducted using multiple cameras to synchronize the timing of the shots or to also synchronize the shots with external measuring devices and lighting. The procedure and precautions for using the external synchronization signal are explained below.

### ■ Inputting an External Synchronization Signal

An external synchronization signal can be input to the SYNC IN terminal with the system. See the chart below for external synchronization input settings.

Menu Display	Description
INTERNAL	Sets external synchronization off, operates independently.
EXTERNAL	The camera synchronizes the signal that was input when the setting is changed to EXTERNAL. The frequency at the time of setting change is displayed, and the system synchronizes signals lower than this frequency. After synchronization setting, shutter speed and resolution can be changed but frame rate can not be changed.

### ■ Outputting an External Synchronization Signal

The system can externally output a synchronization signal. See the chart below for external synchronization output settings.

Menu Display	Description	Signal Type
SYNC POS	Outputs a positive polarity vertical synchronization signal.	CMOS output, positive polarity
SYNC NEG	Outputs a negative polarity vertical synchronization signal.	CMOS output, negative polarity

## 1.3.5 Synchronization with a variable frequency

When the system receives synchronization signal via external input terminals, the system can operate with the frame rate and resolution specified at the start of recording as the maximum value, following the synchronization signal up to 1 Hz even in the recording mode.

### NOTE

When an input sync signal is variable, or when it exceeds the upper limit frequency, the output image quality might be poor.

## 1.4 Device Connections

### 1.4.1 Minimum Equipment Connection

The minimum connection for using the camera is as follows.

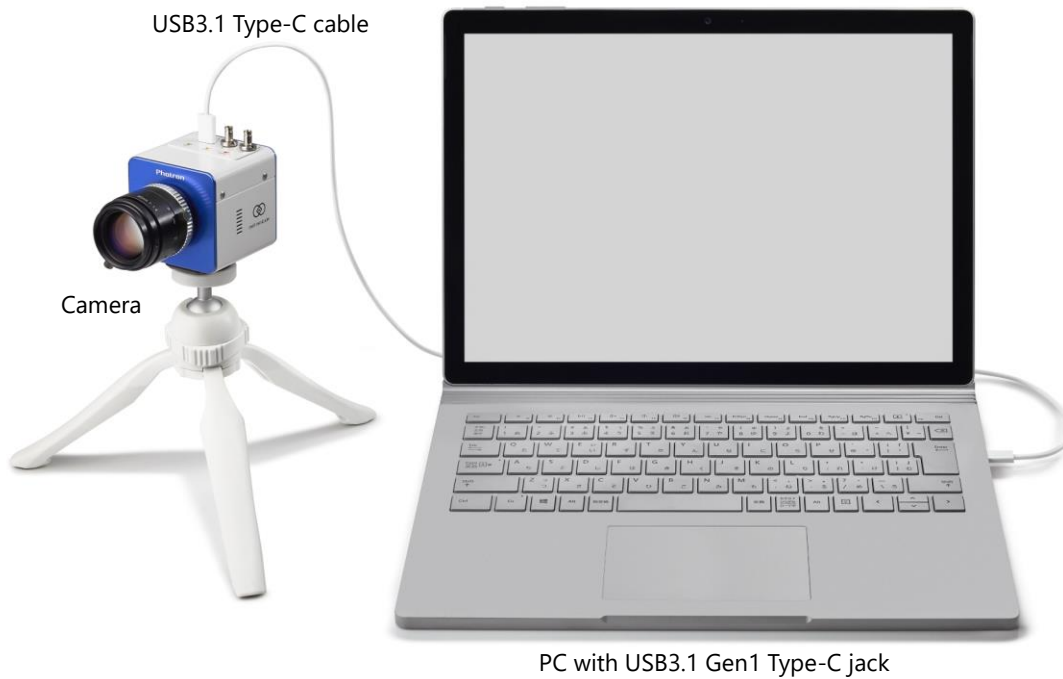

# 2

## Chapter 2 Product Specifications

This chapter explains the system's specifications.



## 2.1 Specifications

### 2.1.1 Product Specifications

Image Sensor	CMOS image sensor
Sensor Resolution	1,246 x 1,024 pixels
Sensor Size	12.8 x 10.24 mm
Pixel Size	10 $\mu$ m square
Frame Rate	For full frame operation: 988 fps For segment frame operation: 31,157 fps
Accuracy of frame rate	50 ppm
Minimum shutter speed	6.5 $\mu$ sec
Lens Mount	C mount
Recording Color Depth	Monochrome: 8-bit
Shutter Method	Electronic shutter (Global shutter)
Recording Method	Real-time transfer system
External Synchronization Input/ Output Signal	2.5Vp-p, negative polarity / positive polarity (switchable), DIN connector (male)
Digital Interface	USB3.1 Gen1 Type-C
Camera enclosure	Unsealed, Air-cooled (with fan)

### 2.1.2 General Specifications

<b>Environment Conditions</b>	
Storage Temperature	-20 to 60 deg C, -4 to 140 deg F
Storage Humidity	85% or less (No Condensation)
Operating Temperature	0 to 40 deg C, 32 to 104 deg F
Operating Humidity	80% or less (No Condensation)
Pollution degree	Degree 2 according to IEC60664-1
Overvoltage category	Category II according to IEC60664-1
Maximum use altitude	2,000 m or lower
<b>External Dimensions</b>	
Camera Body	55.0 (H) x 55.0 (W) x 55.0 (D) mm, excluding protrusion 2.17" (H) x 2.17" (W) x 2.17" (D)
<b>Weight</b>	
Camera Body	280 g, 0.617 lbs

## 2.1.3 Frame rate and Resolution

Frame rate [fps]	Resolution [pixel]
50	1,246 x 1,024
250	1,246 x 1,024
500	1,246 x 1,024
988	1,246 x 1,024
1,000	1,246 x 1,008
2,000	1,246 x 496
5,000	1,246 x 176
10,000	1,246 x 80
20,000	1,246 x 32
31,157	1,246 x 16

### NOTE

- The frame rate can be set in the range of 1 to 31,157 fps.
- The resolution can be set in 16-pixel increments in the vertical direction.

### CAUTION

Depending on the performance of the PC and the cables used, the set recording performance may not be achieved.

## 2.1.4 Shutter Speed List

The shutter speed can be set in increments of 0.01  $\mu$ sec in the open (1/frame) to 6.5  $\mu$ sec range.

# 3

## Chapter 3 Warranty

This chapter explains about the warranty.

## 3.1 About the Warranty

This system has been shipped having undergone rigorous testing. However, in the unlikely event that it malfunctions due to a manufacturing defect, it will be repaired, at no charge, within the warranty period.

### ◆ Warranty Exceptions

The following exceptions will result in fee-based repair, even within the warranty period.

1. Damage or malfunction as a result of fire, earthquake, water damage, lightning, other natural disasters, pollution, or the effects of abnormal voltage.
2. Damage or malfunction as a result of dropping or mishandling during shipment or when moving after purchase or misuse.
3. Consumable goods (cables)
4. When repair, adjustment, or alternation done by an entity other than Photron service has been performed on the system, or damage or malfunction that is determined to be attributed to a fault in the use the product.

For inquires related to malfunction, contact the dealer where the product was purchased, or the nearest Photron office.



### REFERENCE

For inquires related to our product, refer to “4.1 Contact Information” page 18.

# 4

## Chapter 4 Contacting Photron

This chapter lists the contact information to use when contacting Photron if the system malfunctions or if a portion of the manual is unclear.

## 4.1 Contact Information

For inquiries related to INFINICAM UC-1, contact Photron at one of the contact points listed below. Additionally, the following items will be required for verification when inquiring. You are kindly asked to prepare them in advance.

Items Verified	Required Information
Contact Information	Company, school or organization name, customer contact name, contact phone number, contact e-mail address.
Product Name	INFINICAM UC-1
Serial Number	Shown in the nameplate seal.
Condition of the system, nature of problem, etc.	

Contact Information	
In Americas and Antipodes	<b>PHOTRON USA, INC.</b> 9520 Padgett Street, Suite 110, San Diego, CA 92126-4426, USA Phone: +1 (800) 585 2129 or +1 (858) 684 3555 Fax: +1 (858) 684 3558 E-mail: <a href="mailto:image@photron.com">image@photron.com</a> Web: <a href="http://www.photron.com">www.photron.com</a>
In UK, Africa, and India	<b>PHOTRON (EUROPE) LIMITED</b> The Barn, Bottom Road, West Wycombe, Buckinghamshire HP14 4BS, U.K. Phone: +44 (0) 1494 48 1011 Fax: +44 (0) 1494 48 7011 E-mail: <a href="mailto:image@photron.com">image@photron.com</a> Web: <a href="http://www.photron.com">www.photron.com</a>
In Europe outside the UK	<b>Photron Deutschland GmbH</b> Ziegelweg 3, 72764 Reutlingen, Germany Phone: +49 (0) 7121 699 7950 Fax: +49 (0) 7121 699 7943 E-mail: <a href="mailto:image@photron.com">image@photron.com</a> Web: <a href="http://www.photron.com">www.photron.com</a>
In China	<b>PHOTRON (SHANGHAI) LIMITED</b> Room 20C Zhao-Feng World Trade Building, No. 369 Jiangsu Road Chang Ning District, Shanghai 200050, China Phone: +86 (21) 5268 3700 Fax: +86 (21) 5268 3702 E-mail: <a href="mailto:info@photron.cn.com">info@photron.cn.com</a> Web: <a href="http://www.photron.cn.com">www.photron.cn.com</a>
In other areas	<b>PHOTRON LIMITED</b> 21F, Jinbocho Mitsui Bldg., 1-105 Kanda Jimbocho, Chiyoda-Ku, Tokyo 101-0051, Japan Phone: +81 (3) 3518 6271 Fax: +81 (3) 3518 6279 E-mail: <a href="mailto:image@photron.co.jp">image@photron.co.jp</a> Web: <a href="http://www.photron.co.jp">www.photron.co.jp</a>



### NOTE

Contact Photron for sample software, SDKs, and other technical information.

# **INFINICAM UC-1**

Hardware Manual      Rev. 4.03 E

Publication Date: May 2021

Publisher: PHOTRON LIMITED

21F, Jinbocho Mitsui Bldg.,

1-105 Kanda Jimbocho, Chiyoda-Ku, Tokyo 101-0051, Japan